

**DSK1000 Series Air/Gas Flow Sensor**

# DSK1000 Series Air/Gas Flow Sensor

Thermo's DSK1000 Series is a pitot averaging air / gas flow measuring station with "Integral Flow Straighteners" designed for industrial process air and gas flow measurement.

The DSK1000 Series is ideal for process control applications where high repeatability must be maintained even when there is very little straight run of pipe available.

The integral flow straighteners eliminate the effects of turbulence while providing the equivalent of 7-9 diameters of straight run. The multi-point pitot array features Thermo's patented "Kiel Shrouded" impact ports and "Hemispherical Static Wands" positioned parallel with the flow stream, for true static measurement.

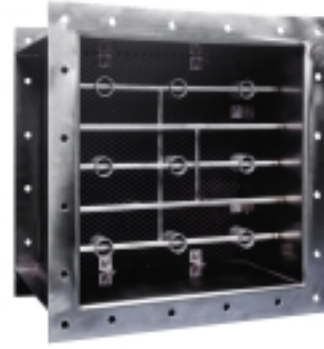

- Accuracies of  $\pm 1.0\%$  of Reading
- Repeatabilities of  $\pm 0.1\%$  of Reading
- Maximum Turndown of 25:1
- 12 inch Flange to Flange Dimension

## Model Number Description

SERIES & CASING DESIGN AND MATERIAL	
DSK10 - Circular Carbon Steel, Flange to Flange Dimension of 12 inches	
DSK12 - Rectangular Carbon Steel, Flange to Flange Dimension of 12 inches	
DSK14 - Circular Stainless Steel, Flange to Flange Dimension of 12 inches	
DSK16 - Rectangular Stainless Steel, Flange to Flange Dimension of 12 inches	
DSK1X - Special (consult factory)	
SENSOR ASSEMBLY	
2 - 304 Stainless Steel Pitot Array with Hemispherical Static Wands. See note this section on Kiel Shrouds.	
5 - 316 Stainless Steel Pitot Array with Hemispherical Static Wands. See note this section on Kiel Shrouds.	
X - Special. Consult factory.	
<i>Note: Kiel Shrouds not used on (a) Circular sizes of 35.5" diameter or less and (b) Rectangular sizes where area is less than 577 Square Inches.</i>	
FLOW STRAIGHTENERS	
0 - None	3 - 304SS, 6 mil thick, welded each node (for velocities greater than 5000 FPM)
1 - Aluminum	5 - 316 SS Welded construction.
2 - 304SS, welded construction.	X - Special. Consult factory
- SIZE	
CIRCULAR - Inside Dimension and Unit Of Measure.	
RECTANGULAR - Inside Dimensions (both Sides) and Unit Of Measure.	
- FLANGE PREFERENCE	
0 - None	2 - Thermo standard without Holes
1 - Thermo standard with Holes	X - Special. Consult factory.
- OPTIONS	
ZV - Mounted MVA Zeroing Valve. See MVA1000 Specification Sheet	
CF - Companion Flange (Qty. of 2) for installation. Supply existing Duct O.D. with Order.	
MG - Mounting Gaskets (Qty. of 2) for installation. Specify Material when ordering.	
IB - Intake Bell. Mounts on the inlet of the DSK 1000 for outside air intake measurement. Minimizes permanent pressure loss and shapes velocity profile	
TH - Intake Bell Rain Cover	
TC - Temperature Connection, 1/2" NPTF, 316SS, for insertion of Temperature Sensor.	
PC - Pressure Connection, 1/4" NPTF, 316SS for static pressure measurement in Mass Flow Applications.	
RTD - Resistance Temperature Detector, 3 wire device for Temperature Measurements. Option TC included.	
ARTD - Averaging RTD Sensor, 3 wire device for Temperature Averaging. Option TC included.	
QS - Seismic Qualified for Nuclear Applications. Specify seismic zone and response spectrum.	

Note:

1. Flow calculations will be based on conditions supplied at time of order. Temperature Range, Pressure Range, Flow or Velocity Range, Molecular Weight, Gas Composition and Relative Humidity are necessary to insure unit design will meet application requirements. Specify tagging if applicable.

DSK14 2 2 -24" -1 -CF

Typical Model Number

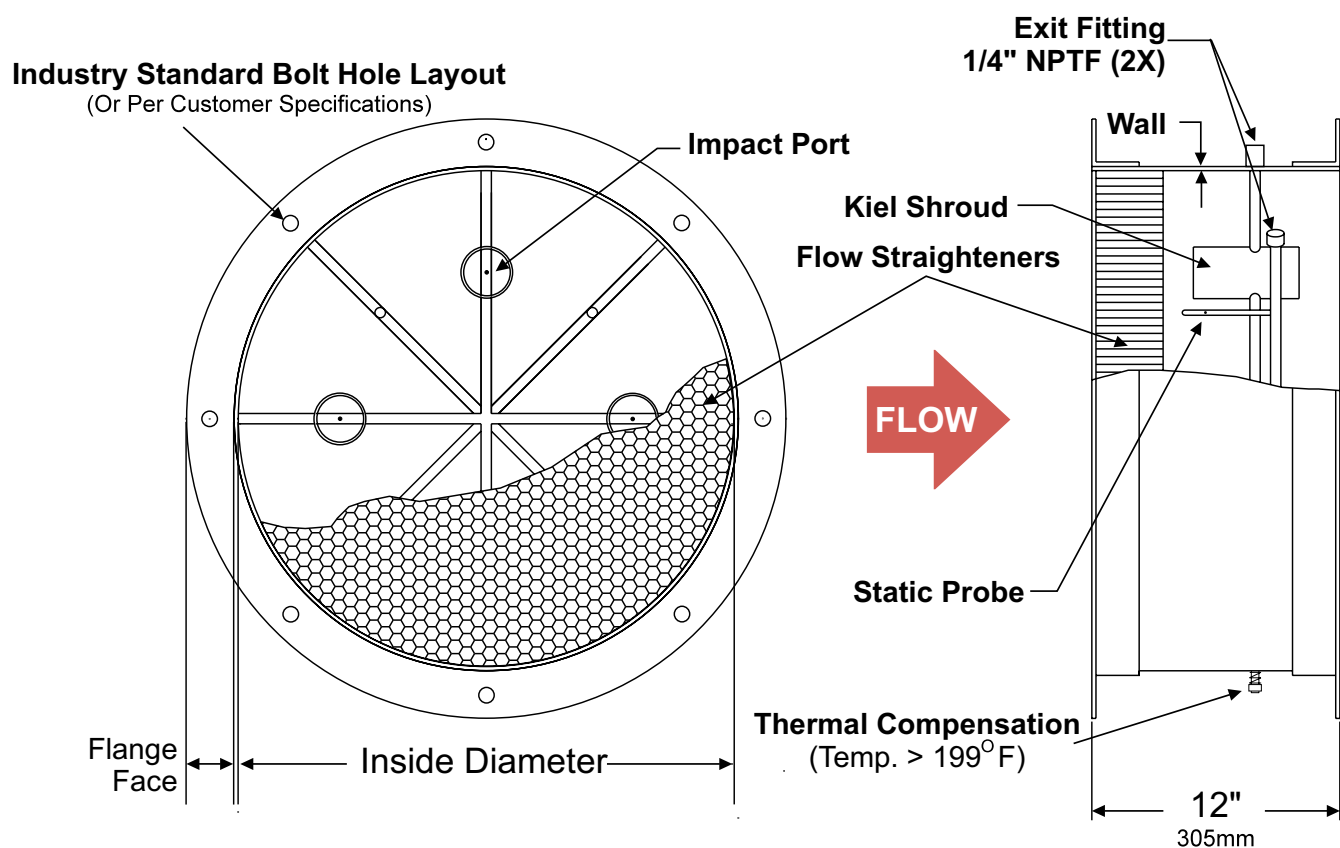

## Circular DSK1000

**Standard Circular DSK1000 - Physical Dimensions**

Inside Diameter	Wall Thickness	Flange Face	Exit Fitting
8" to 24.0" 200 to 611 mm	0.063 Inch 1.6mm	1.5 Inch 38.1mm	1/4" NPTF
24.1" to 34" 612 to 865 mm	0.075 Inch 1.9mm	2.0 Inch 50.8mm	1/4" NPTF
34.1" to 52" 866 to 1321 mm	0.105 Inch 2.7mm	2.0 Inch 50.8mm	1/4" NPTF
52.1" to 72" 1322 to 1830 mm	0.105 Inch 2.7mm	3.0 Inch 76.2mm	1/4" NPTF
72.1" or greater 1831 mm and up	consult factory consult factory	consult factory consult factory	1/4" NPTF

# DSK1000 Series Air/Gas Flow Sensor

---



## Kiel Shrouded Impact Port

- Improves Signal Quality.
- Increases Accuracy While Minimizing Effects Of Turbulent Flow.
- Eliminates Problems Associated With “Yawing” (Angular Position).



## True Static Measurement

- Hemispherical Static Wand Design.
- Measures Actual Static Pressure, No Correction Factors Required.
- Wands Positioned 90° To The Direction Of Flow, Eliminating Velocity Effect Errors.

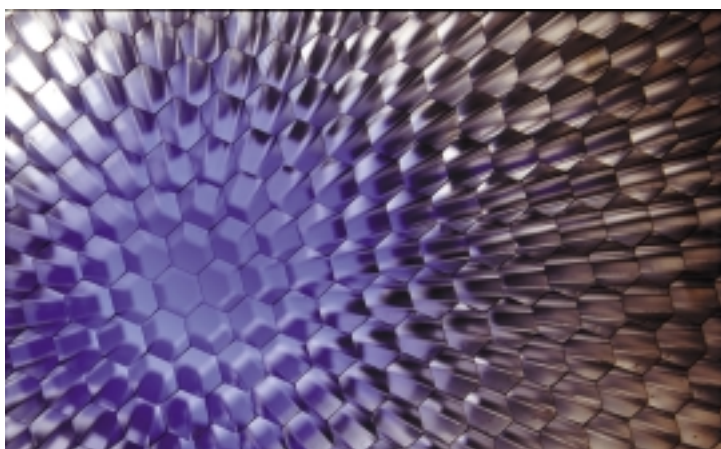

## Flow Straighteners

- Same Conditioning Effect As 7 To 9 Diameters Of Straight Run.
- Removes Much Of The Error Due To Swirl And Other Irregularities In The Flow Stream.
- Provides The Best Compromise Between Low Pressure Loss And Smooth Flow.

---

## DSK1000 Series Proven Applications

- Aeration Basin Flow
- Combustion Air Flow
- Catalytic Denonxing Flue Gas Flow
- Flue Gas Recirculation Flow
- Fluidized Bed Dryer Flow - Pills and Candies
- Overfire Air Flow
- Primary Air Flow to Coal Mills
- Preheated Combustion Air Flow with Fly Ash
- Secondary Air Flow
- Zone Dryer Air Flow - Tobacco Drying / Blending, Film & Paper Drying

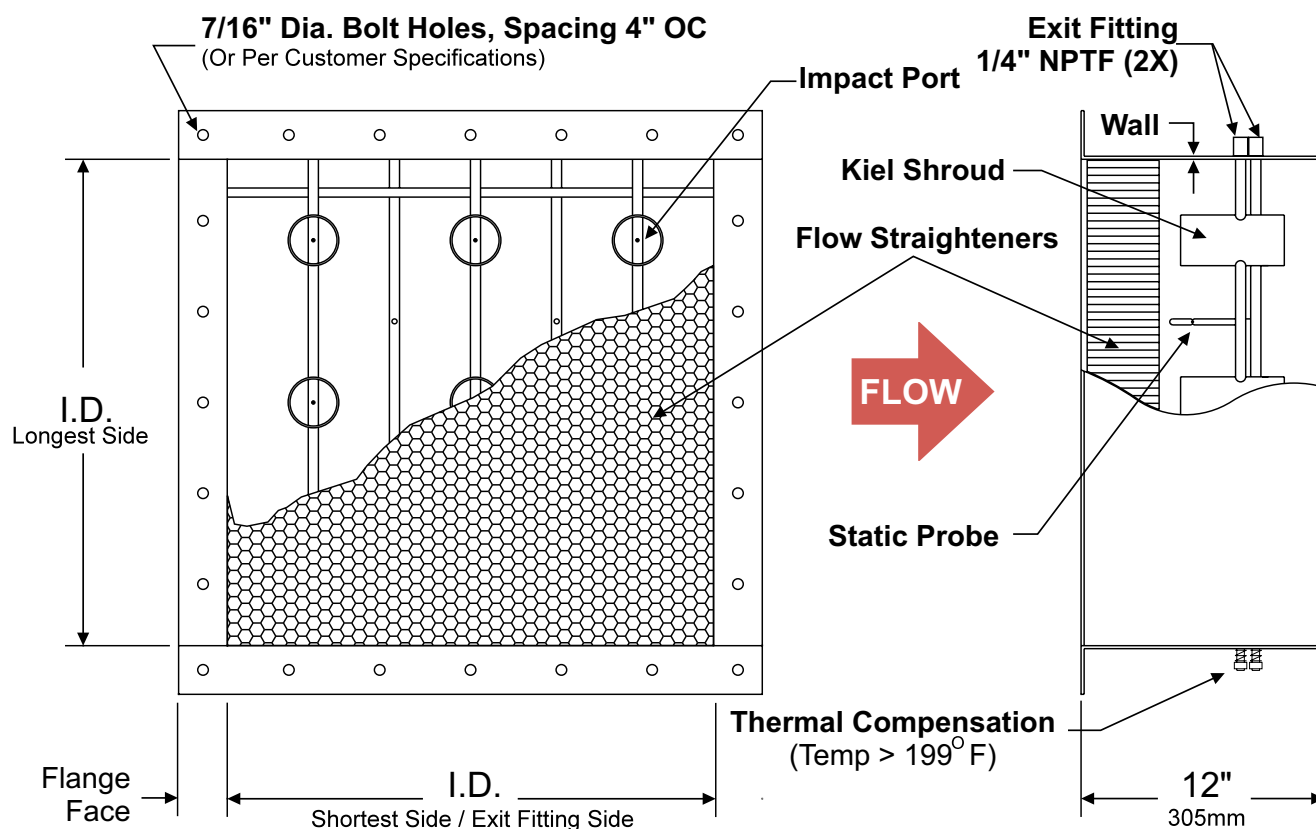

## Rectangular DSK1000

**Standard Rectangular DSK 1000 - Physical Dimensions**

I.D. (longest side)	Wall Thickness	Flange Face	Exit Fitting
10" to 24.0" 254 mm to 611mm	0.125" 3.2mm	2.0" 50.8mm	1/4" NPTF
24.1" to 48" 612 mm to 1220 mm	0.125" 3.2mm	2.5" 63.5mm	1/4" NPTF
48.1" to 72" 1221 mm to 1829 mm	0.188" 4.8mm	2.5" 63.5mm	1/4" NPTF
72.1" and up 1831 mm and Up	0.250" 6.4mm	2.5" 63.5mm	1/4" NPTF

# DSK1000 Series Air/Gas Flow Sensor

## PERFORMANCE SPECIFICATIONS

	CIRCULAR	RECTANGULAR
<b>Accuracy:</b>	Typically $\pm 1\%$ with Flow Straighteners	Typically $\pm 2\%$ with Flow Straighteners
<b>Repeatability:</b>	$\pm 0.1\%$ with Flow Straighteners	$\pm 0.2\%$ with Flow Straighteners
<b>Min/Max permissible measured Differential Pressure:</b>	0.01" to 6.25" w.c. (0.254 to 159 mmwg). This represents a velocity of 400 to 10,000 fpm (2.0 to 50.8 m/s) of air @ 68° F, 14.7 psia / abs.	
<b>Unrecovered Pressure Loss:</b>	Approximately 30% of measured DP <i>Example: At a Velocity of 4000 FPM @ S.T.P., the measured D.P. is 1.0" w.c. The permanent pressure loss is 30% of 1.0" w.c. or .30" w.c.</i>	
<b>Flow Range:</b>	25:1 maximum turndown	

## FUNCTIONAL SPECIFICATIONS

	CIRCULAR	RECTANGULAR
<b>Maximum Static Pressure:</b>	Carbon Steel casing: 6 psig (0.27 bar) @ 325°F (163°C)  304 Stainless Steel casing: 8 psig (0.87 bar) @ 750°F (400°C)	Carbon Steel casing: 1 psig (0.07 bar) @ 325°F (163°C)  304 Stainless Steel casing: 1 psig (0.07 bar) @ 750°F (400°C)
<b>Temperature:</b>	Stainless Steel / Carbon Steel: -200°F to 750°F (-128°C to 400°C)  With Aluminum flow straighteners: -67°F to 300°F (-55°C to 162°C) <i>Higher temperatures possible. Consult factory.</i>	

## PHYSICAL SPECIFICATIONS

	CIRCULAR	RECTANGULAR
<b>Minimum Sizes:</b>	8" (200mm) Dia.	10" (250mm) per Side. <i>For smaller sizes, consult factory for availability &amp; pricing</i>
<b>Sensors:</b>	304 or 316 Stainless Steel w/Argon welded joints	
<b>Process Connections:</b>	316 Stainless Steel, 1/4 NPTF	
<b>Flow Straighteners:</b>	3/8" Hexagonal cells either Aluminum (3.5" Deep), 304 or 316 Stainless Steel (2.5" Deep). Stainless Steel is of welded construction.  For high velocities reinforced Flow Straighteners (6 mil. thick, welded every node) are available.	
<b>Casing/Flanges:</b>	Carbon Steel (epoxy coated with rust inhibiting primer), 304 Stainless Steel or 316 Stainless Steel. All joints are continuously seam welded. Flanges with bolt holes are standard. For other materials, coatings, etc. consult factory for pricing & availability.  <i>Note: End flange mounting hardware not supplied.</i>	

## INSTALLATION

Configuration	WORST CASE CONDITIONS		RECOMMENDED INSTALLATION	
	Accuracy	Rep.%	Upstream	Downstream
<b>Fan Inlet w/Bell</b>	1.0%	0.10%	1 Dia.	2 Dia.
<b>Fan Outlet</b>	1-2%	0.10%	3 Dia.	2 Dia.
<b>Compressor Outlet</b>	1-2%	0.10%	3 Dia.	2 Dia.
<b>Elbow or Tee</b>	3-5%	0.10%	5 Dia.	2 Dia.
<b>2 Elbows same plane</b>	4-6%	0.10%	7 Dia.	2 Dia.
<b>2 Elbows Different Planes</b>	5-7%	0.10%	8 Dia.	2 Dia.

WORST CASE CONDITIONS = No Upstream Or Downstream Straight Run

RECOMMENDED INSTALLATION = Number Of Upstream And Downstream Straight Run Necessary For Optimum Performance.

For Installation Configurations Not Shown, Consult Factory.

## SPECIFYING THE DSK1000

Flow measuring station shall be of the pitot averaging type. The pitot array shall be encased in a flanged section (spool piece) with air flow straightening vanes mounted at the inlet. Flange to flange dimensions shall be 12 inches. All components shall be constructed from 304SS/316SS or epoxy painted carbon steel, all continuous weld.

Air flow straightening vanes shall have 3/8 inch hexagon cells with a Length/Diameter Ratio of 7 to 9. Impact ports shall be shrouded with kiels to reduce noise and improve velocity profile at the point of measurement. Static pressure shall be measured by hemispherical tipped static wands, aligned parallel with the direction of flow. All process connections shall be 1/4" NPTF. Accuracy / Repeatability shall be  $\pm 1.0\%$  /  $\pm 0.1\%$  with a flow turndown range of 25:1.

## About Thermo

For over 20 years, Thermo Electron has been the recognized leader in the measurement of air/gas flow and very low differential pressure in industrial applications. Thermo offers a complete line of pitot/static probes and arrays, D.P. Transmitters, the unique Nozzle Pitot flow sensor and a complete family of Current to Pressure (I/P) and Pressure to Current (P/I) Transducers.



### Thermo Electron Corp.

1410 Gillingham Lane  
Sugar Land, Texas 77478  
Telephone: (713) 272-0404 Fax: (713) 272-2273

Represented By: